

Elevator

SJT-WVF5-K

BL2000-BKT-Vn/FR2000-BKT-Vn



III

1

6

BX-100

17

51

I
...586

.....

.....59

.....61

616G5 676GL5-JJ62

G7A64

G11UD66

2005-4-2568

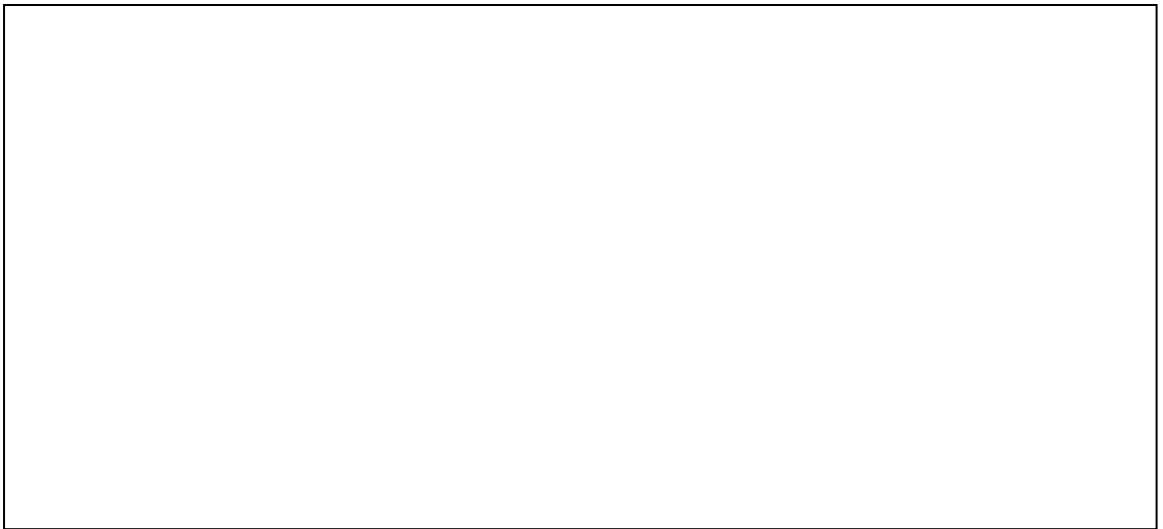

████████████████████

1.2

1.3

1.4

HNB

%	%	%	%
:	%	:'	:(
&	&	&	&

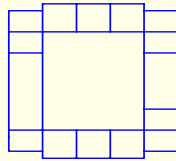

➤

œ E g î x





--	--	--	--	--	--	--	--





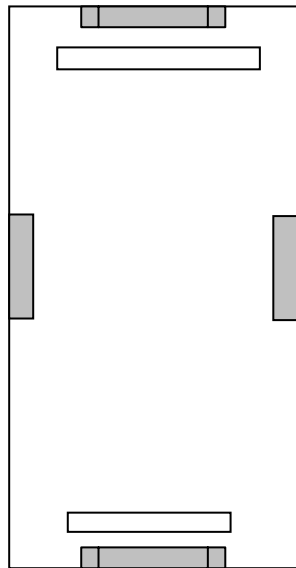







fP&

f&L

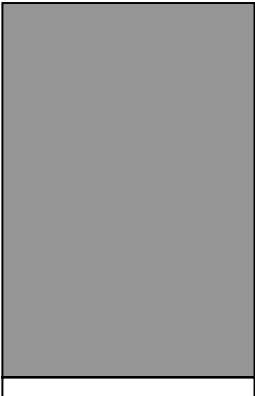

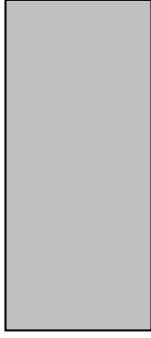
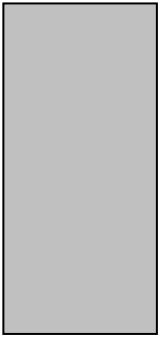

BX-100

3.1



3.2

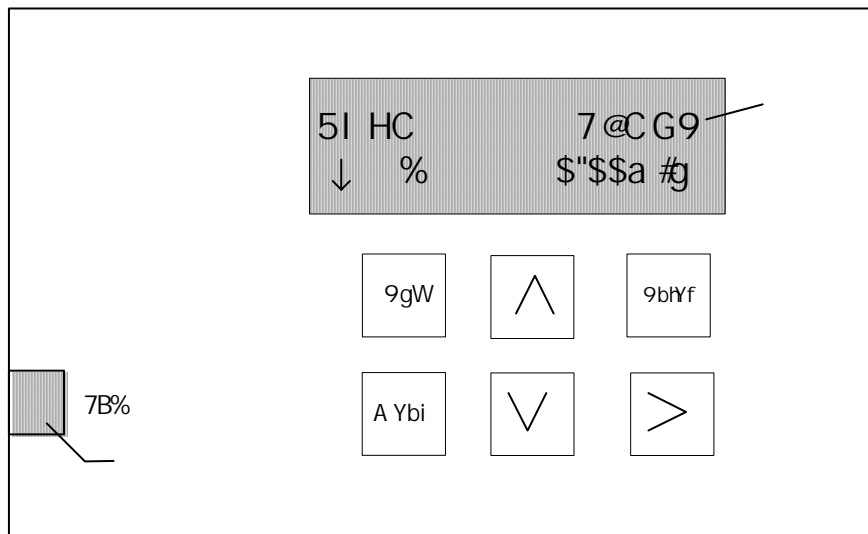

3.3

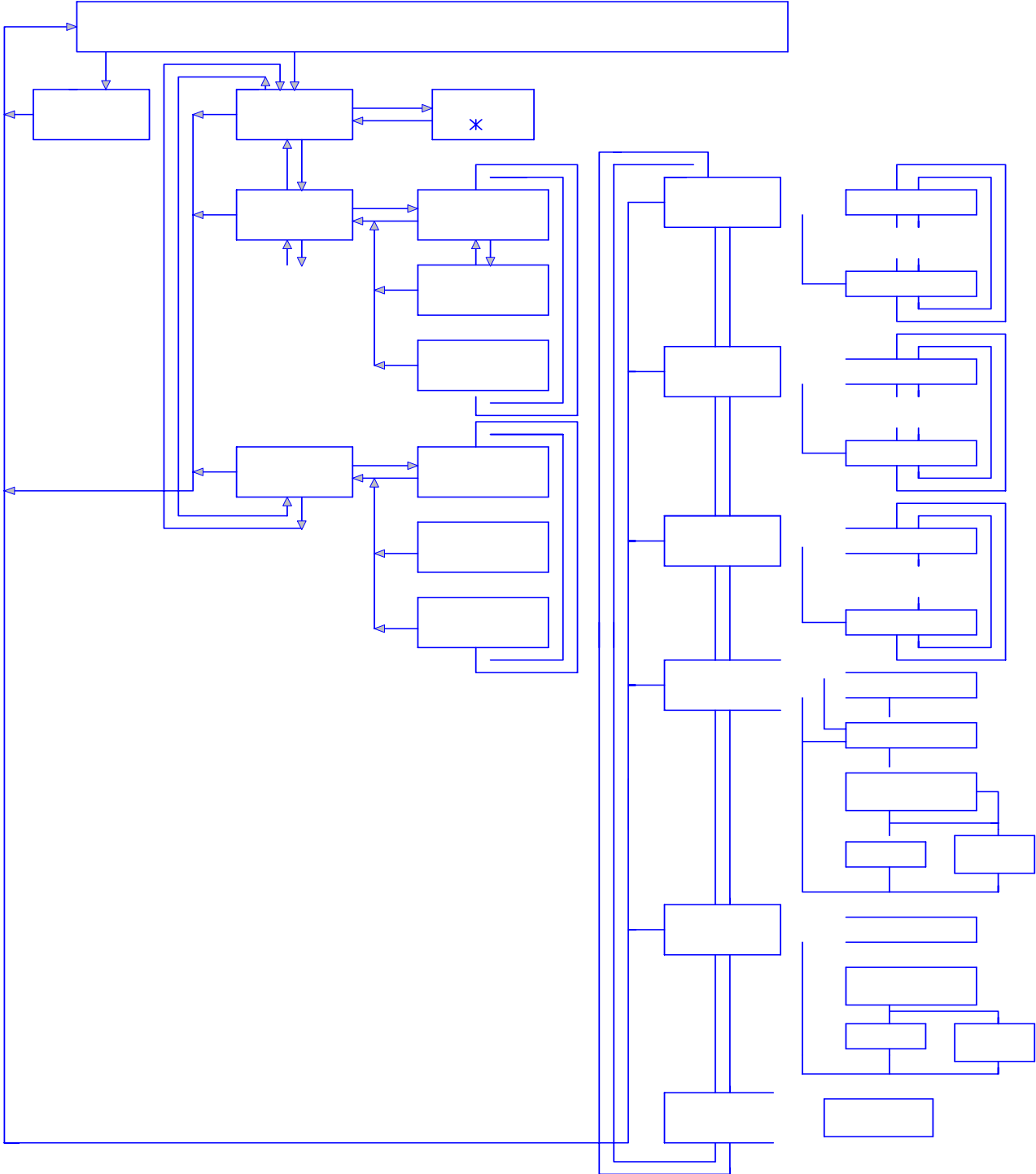



INSP ER=10 CLOSE
↓ 1 0.00m/s

-
-
-
-

—
—

.....



6@ Vta . C?
Gmg Vta . C?

-
-

—
—
—
—



Input Password 0000
Enter

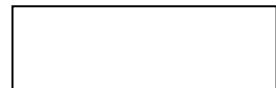
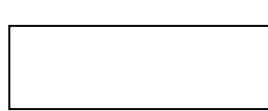
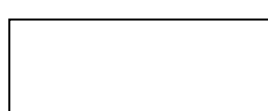
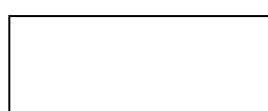
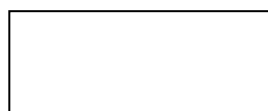
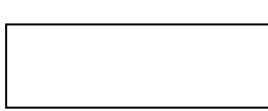
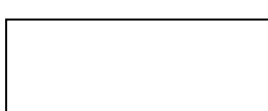
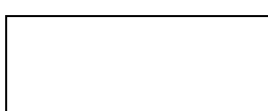
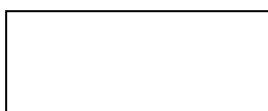
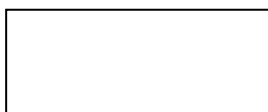
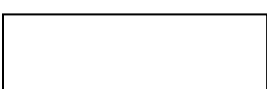
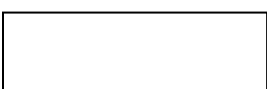
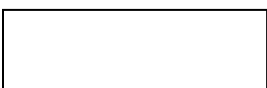
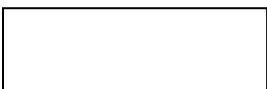
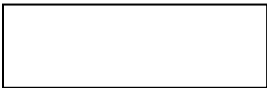
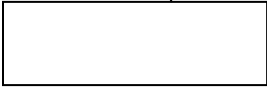
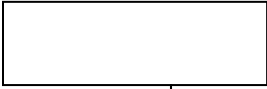
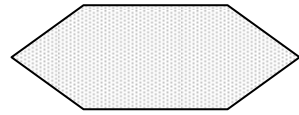
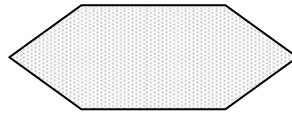
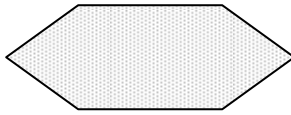
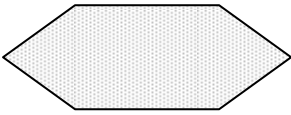

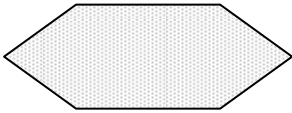



		Call Input		
		Hoistway Data		
		Floor Data		
		Speed Feedback		
		I/O Value		
		Run Report		
		Fault Report		
		Encoder Apprais		
		Input Apprais		
		Software No		
		I/O Input		
		I/O Output		
		I/O Car Data		



		Total Floor	--			
		Homing Floor				
		Set Time	--			
		Open Door Time				
		Open Delay Time				
		Homing Time				
		Start Time				
		Stop Time				
		Fire Floor		—		
		Parking Floor		—		
		Input Type				

		Two Door Mode				
		Fire Mode				
		Parallel No				



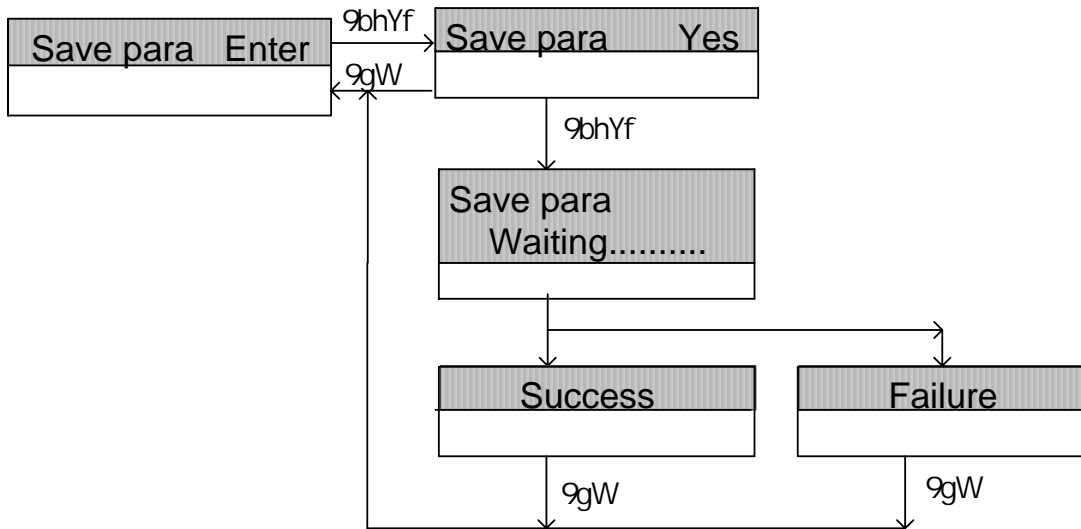

-
-

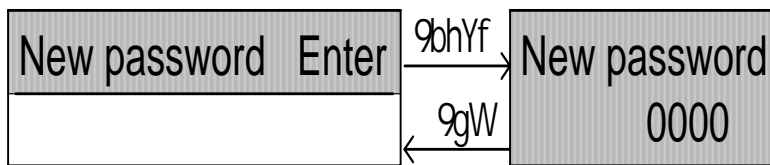

3.4



-
-

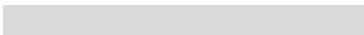

Call Input Enter

I S XEnter

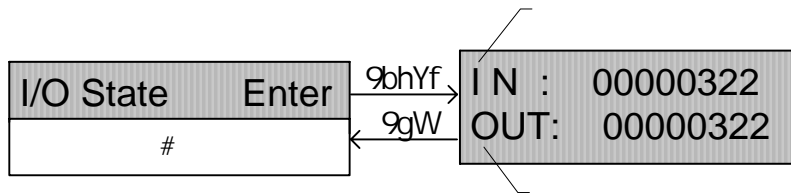

```

      =B 1$$$$$' &&ž   CI H1$$$$$' &&
      =B 1%$$$$$$%$ž  CI H1%$$$$$$%$
L$  L%  L&  L'  L(  L)  L*  L+  L,  L-  L%$  L%%
$   %   $   $   $   $   %   $   %   $   $   $
L%&L%  L%(  L%)  L%*  L%+  L%  L%  L&$  L&%  L&&  L&'
$   $   $   $   $   $   $   $   $   $   $   $
M$  M%  M&  M  M(  M)  M*  M+  M  M  M%$  M%%
$   %   $   $   $   $   %   $   %   $   $   $
M%&M%  M%(  M%)
$   $   $   $

```

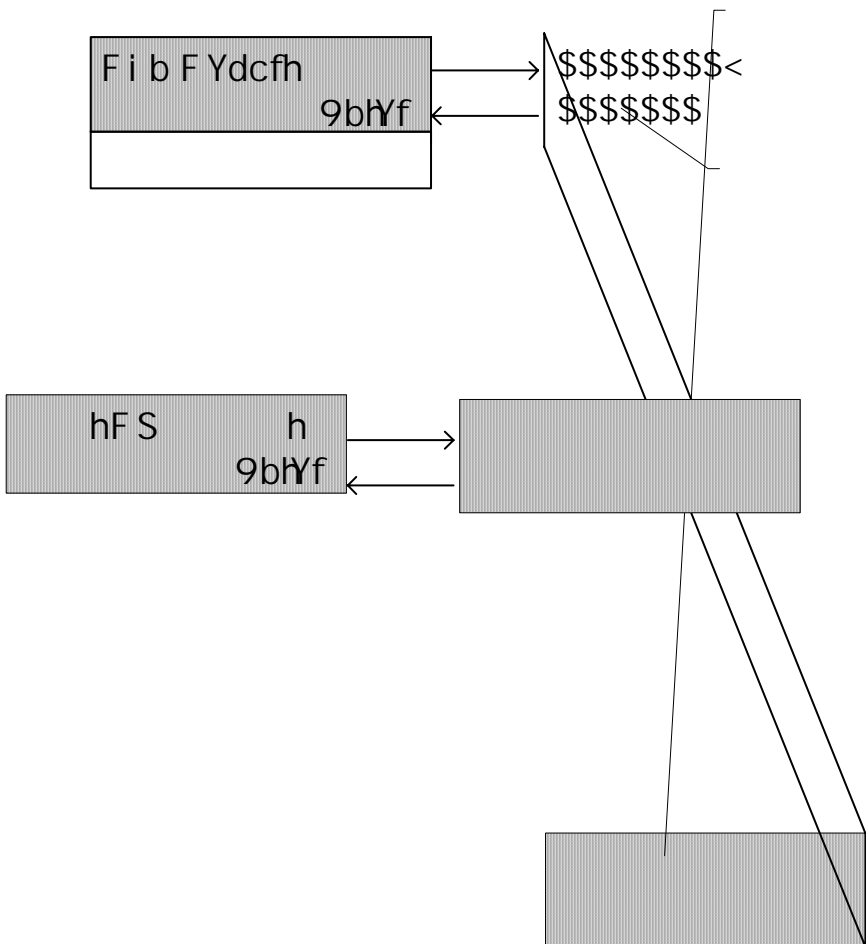

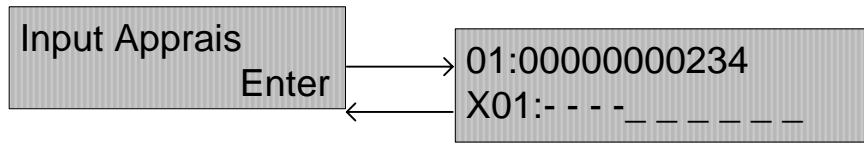
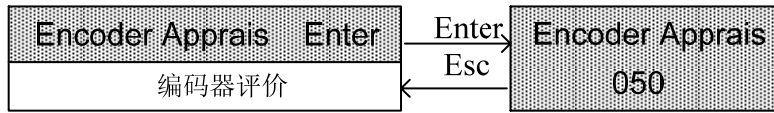

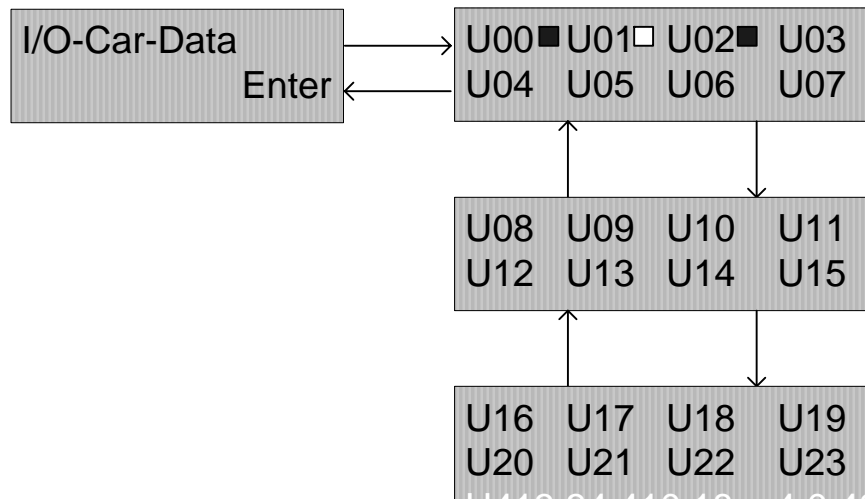
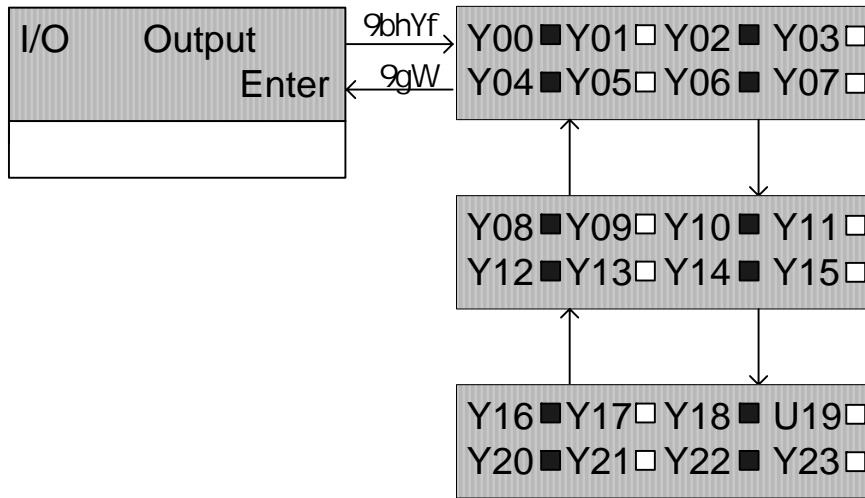



%

9bhYf

.....

&

General para
Enter

HchU : `ccf %&



.

Set Time 00-00-00 00:00



Open Door Time 000s



Open Delay Time 000s



Homing Time 000s



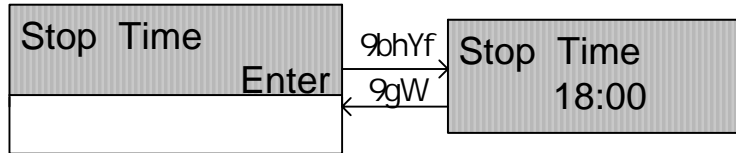
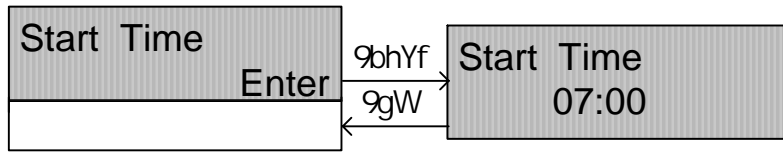

Fire Floor	01

Parking Floor	01

-
-
-
-

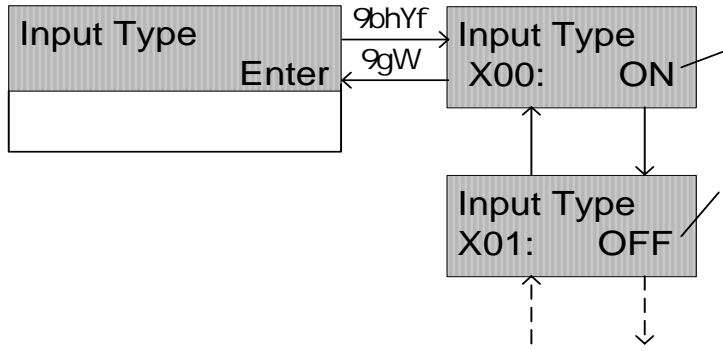

Set Stop Floor
Enter

Enter

Esc

Set Stop Floor
1: ON

Set Stop Floor
2: OFF

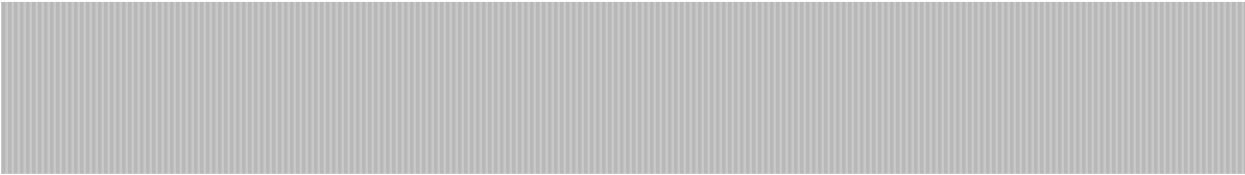

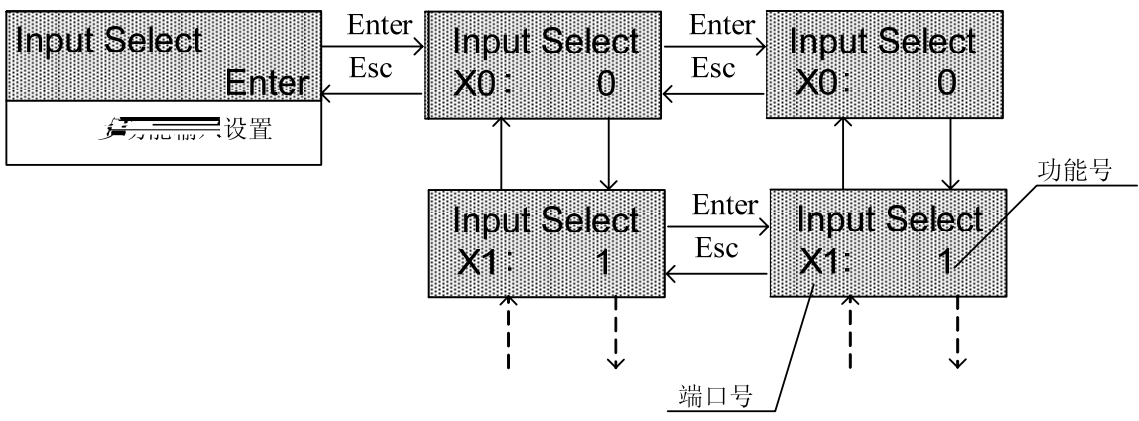

-
- -

X0 1 X1

21

-

Output Select
Ente

Output Select
YU: 0





Runing para
Enter

-
-
-

Car Speed
1.60m/s

Motor Speed
1350rpm

-
-

Pulses
0600



Insp Speed 0.30m

8Tf 9.031 0 0 9.031 310.68 52.4003 Tmfc> Tf 9.031 0 0 9.031 92.22 766.4003 Tmfc>

Zero Speed 0005r

L) #

➤
➤

➤
➤

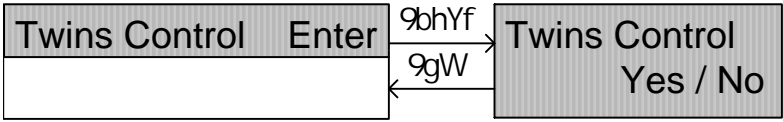



.



.



.

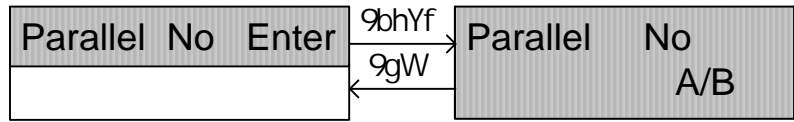
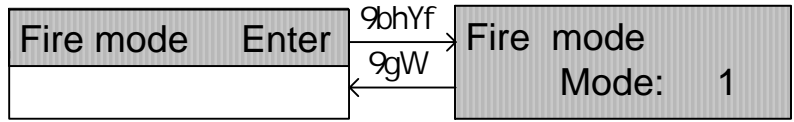

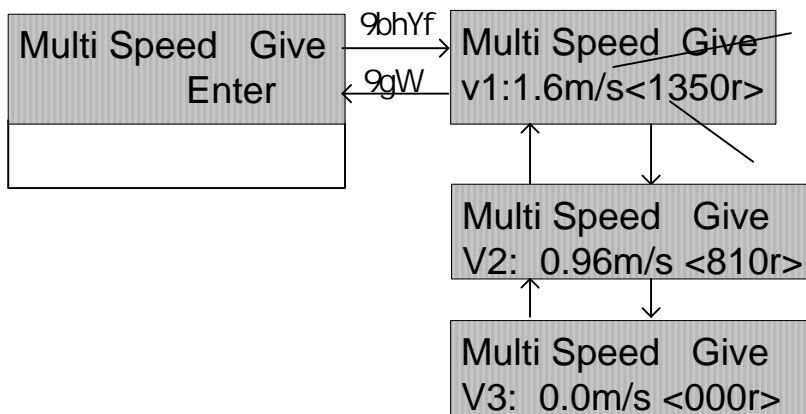
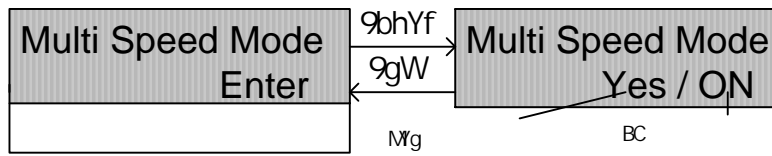
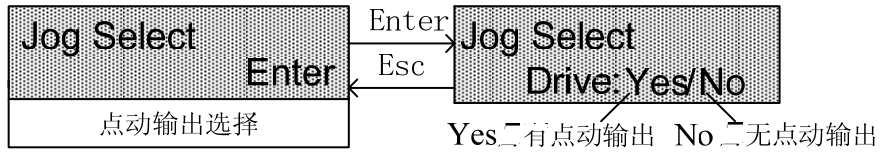

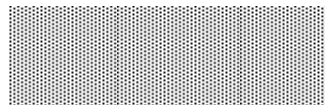
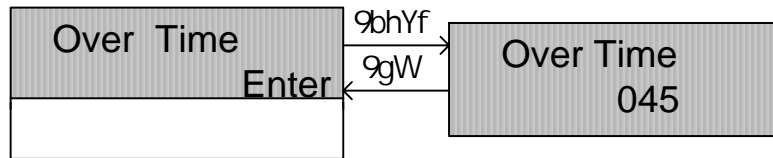
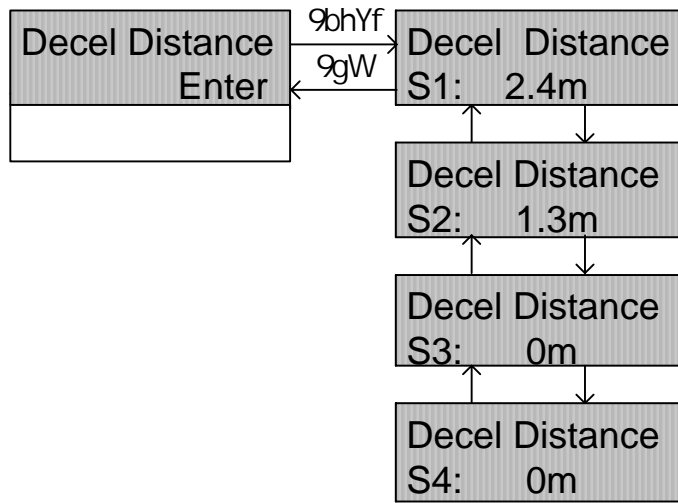

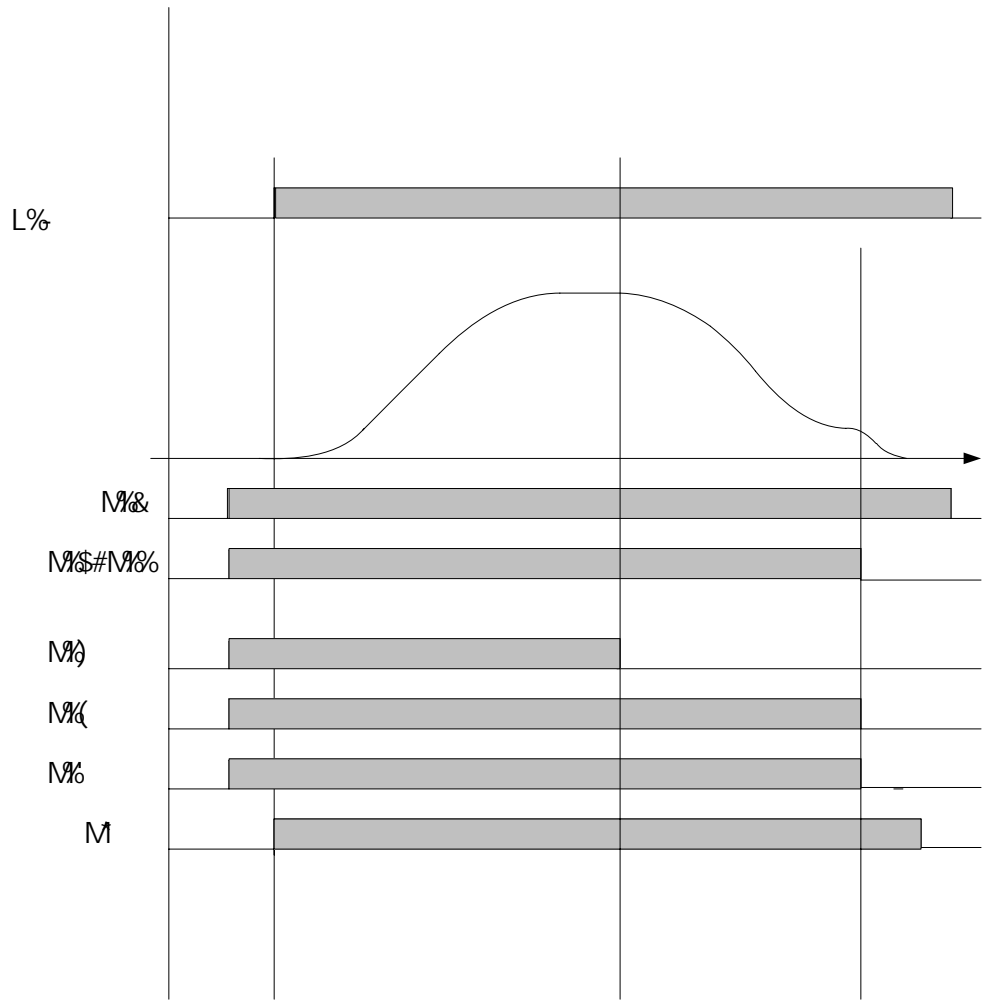

4.1



4.2

4.3



- -
 -
 -
- ∩



4.4



4.5

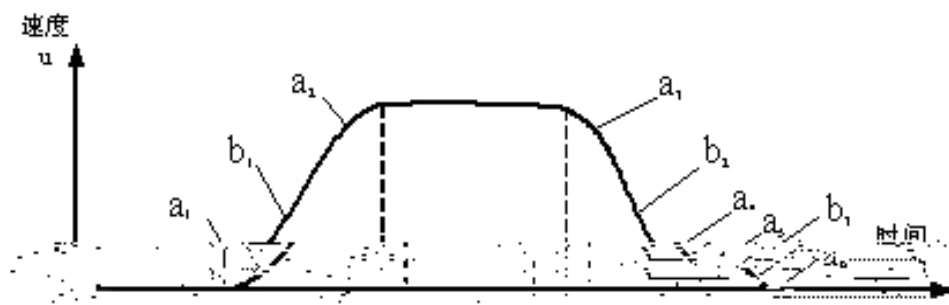

[Redacted text block]

ž
&') ± \$"%&

\$" a#g"

ž fl 7

ž ž

I



-
-
-
-

)

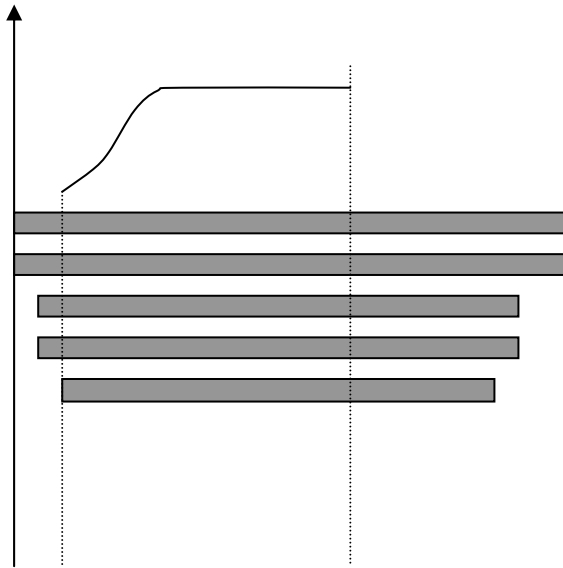

-
-



*

616G5 676GL5-JJ

G7A

	5% \$\$	@78		\$					
	5% \$%			&	58J5B798				
	5% \$&			'	D,				

			<N g]d
9& \$&			5
9& \$'			
9& \$(\$* \$%K
9& %%			D,
: % \$%	D,	D,	D,
: % \$&	D, D, C	%	
: % \$'	CG	\$	7% \$&
: % \$(89J	\$	7% \$&
: % \$*	D,	%	D, 1 %Zb #až b1\$ž% a1% ' &
: % \$,	CG	%)	CG : % \$, %\$\$: % \$-
: % %\$	89J	' \$: % %\$ 89J : % %\$: % %%
: % %%	89J	%	
<% \$'	G)	'	'
<% \$(G*	((
<% \$)	G+))
<% \$*	G	:	*
<% \$+	G-	:	+
<% \$,	G%\$	+	,
<% \$-	G%&	*	-
<% %\$	G%&	-	%\$
<& \$%	A% A&	' +	
@! \$(\$	\$J
@! \$%)	
@! \$)		%	
@! \$+		%	
C% \$%)	
C% \$'	#		

G11UD

: \$&		%	
: \$'	%) \$<n	
: \$(%) \$<n	
: \$)	%	' , \$J	
: \$*	%	' , \$J	
: \$+	%	' ") G	
: \$,	%	\$" \$%G	
: %%			%\$%
: %&		\$") a] b	C@%
: %)) \$<n	
: %*		\$ <n	
: &'		\$' (<n	
: &(<		\$" ' <n	
: &)		\$" %<n	
: &*		%?<n	
: &+		\$	
: ' *	' \$Fm	\$	
: (\$	%	&\$	
: (%	%	&\$	
9\$%	L%	\$	
9\$&	L&	%	
9\$'	L'	&	
9\$(L()	
9\$)	L))	
9\$-	L-	-	
9/\$	&	' ") g	
9/%	&	' ") g	
9/&	'	' ") g	
9/%	'	&') g	
9/((% g	

7C)	%	, <n	
7C*	&	, <n	
7C+	'	' <n	
7%\$	*	' \$<n	
7%%	+) \$<n	
D\$%		†	
D\$&		†	
D\$'		†	
D\$*		†	
D\$-			
C\$%		%	%
C\$&		\$" \$\$\$	
C\$'		†	
C\$(5GF D fl t	&\$	
C\$)	5GF =	\$" %	
C\$*		\$" \$'\$	
C\$+	5GF D %)	
C\$,	5GF D &	%\$	
C\$-	5GF D fl t	&\$	
C\$%		\$" \$\$) G	
C%&	-	\$ %	
C%G	G %	&\$	G
C%G	G (&\$	G
C%G	G)	&\$	G
C%G	G *	&\$	G
C%G	G +	%	G
C&\$	G ,	%	G
C&%	G -	' \$	G
C&&	G %\$	' \$	G
C +		\$" \$	
C ,		\$" '	

× _____
Of #a] b]

2005-4-25

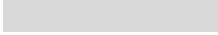

' 9F& % %
(@9F&% &a#g
) @9F&& &a#g
*"

6fYU_ 7\YW_ H] aY &\$\$\$ag

6YYd XY` Um h] aY) \$\$ag

@lad cZZ h]aY
%a]b

